



# DG-2000™ GROUP MANAGER



**DG-2000™  
GROUP MANAGER**

The DG-2000™ Group Manager adds graphics, recipe management, trending and touch-screen operation to the DISOCONT® Gravimetric Control Family. Up to 16 gravimetric screw feeders, weighfeeders, solids flow meters or pumps can be graphically configured and monitored using the DISOCONT® compatible, DG-2000™ Group Manager. The DG-2000™ software itself is Windows-based and comes pre-installed on a CP-3 Industrial PC. Pre-formatted, dynamic color-graphic displays show the operating status of all feeding devices at once, or each device independently. Alarms, feed rates, hopper levels, material usage, and operating status are all displayed. Additionally, a touch-screen and graphically-displayed keys, allow you to easily view more detailed information such as performance graphs or recipe/formula configurations. DG-2000™ software only, can also be purchased and run on either a desktop or laptop PC you supply.

The key to affordability was the development of a special tool kit that enables us to quickly and cost efficiently, configure a series of graphic displays to match the number and type of feeding devices being controlled. Trend/control charts, master-rate and master-slave relationships, operating parameters (feed rates, totalizer values, material levels, out-of-tolerance alarms, etc.), recipe setup, and management screens are all included. Since the software is “configured” rather than custom-designed, development time is much shorter and costs are much lower than you would expect.

## TYPICAL DG-2000™ COMMUNICATION NETWORK

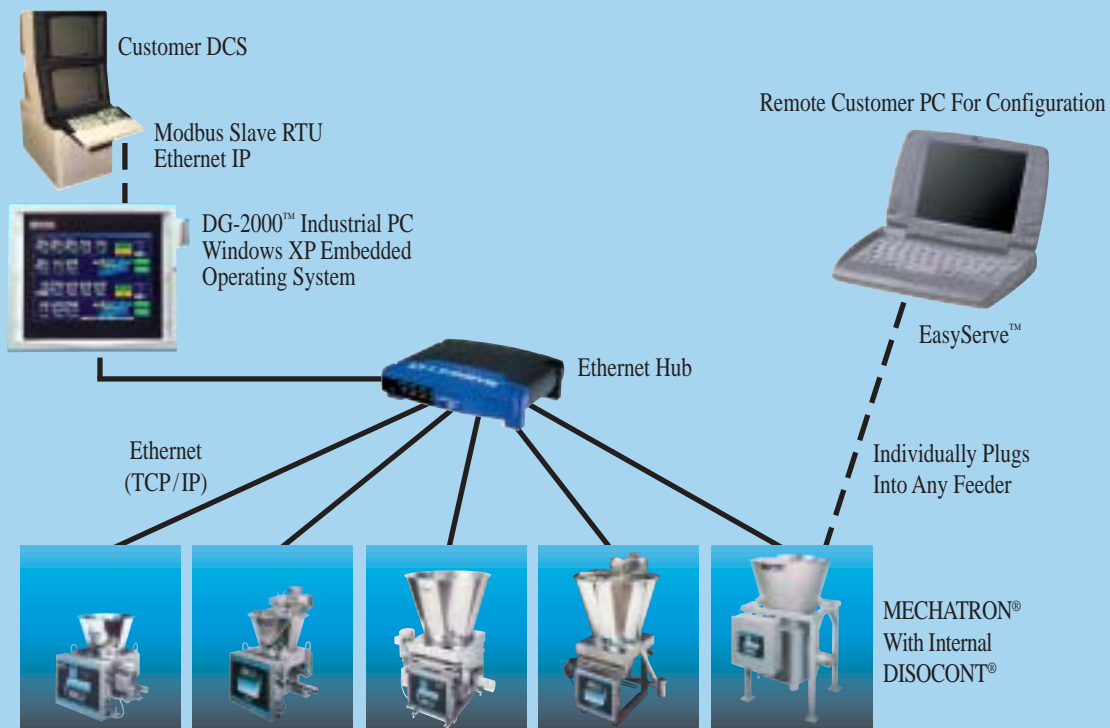

**SPECIFICATIONS**

**DG-2000™ SOFTWARE:**

**Type –**

- SCADA (Supervisory Control And Data Acquisition)
- EasyServe™ configuration and diagnostic software tool kit is optionally available.

**Feeder/Scale Inputs –**

- Standard software version supports up to (16) DISOCONT® controller-based feeder/scale systems. Support for (32) feeder/scale systems is optionally available.

**Communications –**

- High speed fieldbus (Ethernet).
- DISOCONT® compatible RS485 Multi-drop service bus is optionally available.

**Features & Functions –**

- Graphic display of the operational status of all connected feeders/scales.
- Graphic operational close-up for each feeder/scale.
- Feeder/scale specific trend – graph for any (1) of (4) process variables.
- Multiple feeder/scale trend – graph.
- Data logging and graph for up to 12,000 data values.
- Supervisory configuration of feeder/scale parameters.
- Networked feeder/scale configuration optionally available.
- Master rate configurations.
- Formula – recipe setup and file management.
- Single or multiple security code operational protection.

**CP-3 INDUSTRIAL PROCESSOR SPECIFICATIONS:**

SCHENCK AccuRate's CP-3 industrial processor powers the DG-2000™ Group Manager software for gravimetric feeding systems. The CP-3 features a large, bright touch screen, optional Thumb Drive data storage, and a space efficient enclosure.

**Other CP-3 features include:**

- VIA C3™ processor.
- 512 Mbytes RAM.
- 1 Gbytes Compact Flash (CF) for XP embedded.
- 64 Mbytes Compact Flash (CF) for Formula Storage.
- 1024 x 768 15.1" LCD SVGA Color Display.
- Windows XP embedded.
- DG-2000™ Group Controller Software.
- Panel or NEMA 12 Enclosure Mounting Configurations.
- DG-2000™ Group Controller handles ambient temperatures up to 122 degrees F (50 degrees C).
- Internal 12V DC power supply.

**Power Requirements –**

- 110V AC, Single Phase, 60 Hz (customer supplied).

SCHENCK AccuRate's CP-3 Industrial Processor and DG-2000™ Group Manager software are designed specifically for use with DISOCONT®, DISOMAT B Plus, and INTECONT® Plus Gravimetric Controllers.

VIA C3 is a trademark of VIA Technologies, Inc.



**Main Operations Screen**

This display gives the operator a performance overview of all feeding devices. Color and alphanumeric text are used to show run status, alarms, and key process information (feed rates, setpoints, hopper levels, and totalizer values). The optional CP-3 Thumb Drive allows you to easily transfer data to and from a PC.

### Device Specific Operations Screen

This display provides detailed operational information for a specific feeding device, including a performance or trend chart. In addition to feed rate, setpoint, hopper weight, totalizer values and alarms, operating status and speed can be viewed. If the feeding device is not part of a master-rate configuration, feed rate setpoints can also be changed from this screen.



### Formula Setup and Management Screen

This screen is used to configure, store, and retrieve master-rate or master-slave operational configurations. Enter the master-rate, then select the slave devices and enter the percentage of the master-rate they are to run at. Function keys then enable the setup to be stored to or recalled from the DG-2000™'s resident compact flash drive.



### Performance/Trend Screen

Performance graphs or trend lines can be simultaneously displayed for all or a select group of the active feeding devices. Color is used to distinguish one from the other. The plots themselves represent a 1200 data point subset of a data log containing up to 12000 values. Selecting an individual point on any one of the graphs will cause the value of that point to be displayed along with a date and time stamp. Perhaps best of all, the DG-2000™ configured software is PC compatible. Run it on a desktop or laptop you supply or choose the CP-3 Industrial PC with a keyboard and touch-screen that we recommend. Again, you can decide what level is right for you.

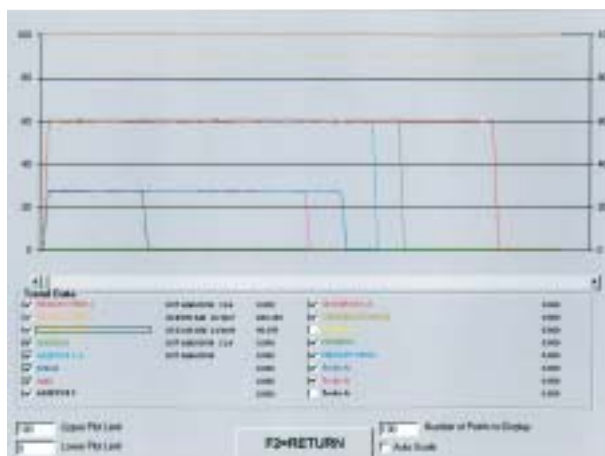

**CP-3 INDUSTRIAL PC**

**PANEL MOUNT ENCLOSURE**

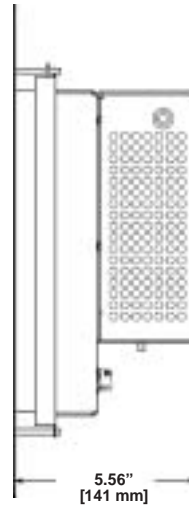
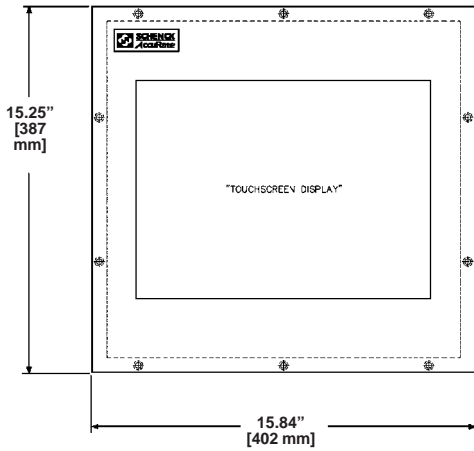

**WALL MOUNT ENCLOSURE (OPTIONAL)**

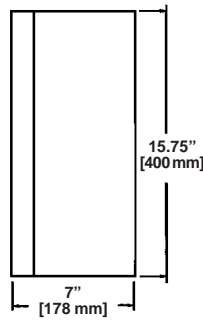
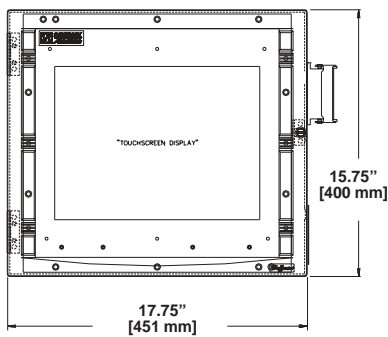

Hoffman Concept® Operator Interface Enclosure

Material: 16 gauge steel.  
7" depth.

Color: ANSI 61 gray polyester powder coating.

Rating: NEMA Type 12; CSA Type 12; IEC 60, IP55.

**WALL MOUNT ENCLOSURE WITH PEDESTAL (OPTIONAL)**

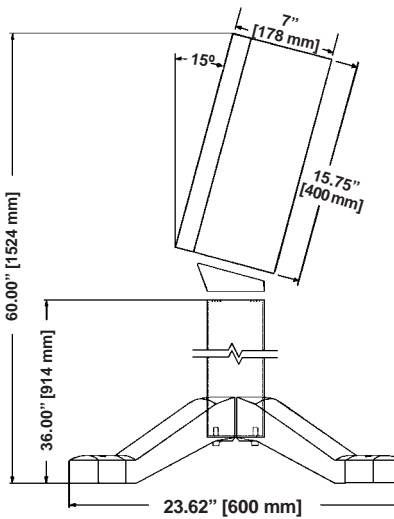
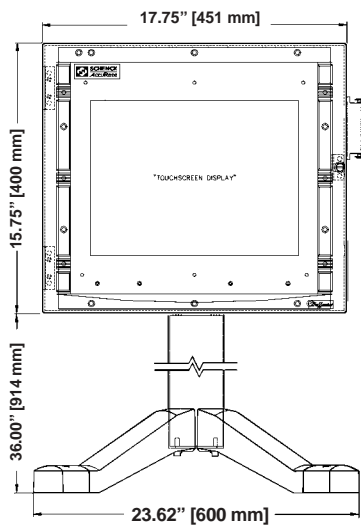

Hoffman Concept® Operator Interface Enclosure With Pedestal

Enclosure Material: 16 gauge steel.

Pedestal Material: Aluminum.

Pedestal Height: 36 inches (915 mm).

Pedestal Legs: (4) with levelers.

Color: ANSI 61 gray polyester powder coating.

Rating: NEMA Type 12; CSA Type 12; IEC 60, IP55.

Note: Enclosure is angled 15° for optimum viewing.

**For more information, please call 1-800-558-0184 or Fax: 262-473-4384**  
**Web site: [www accuratefeeder.com](http://www accuratefeeder.com) • E-mail: [mktg@accuratefeeder.com](mailto:mktg@accuratefeeder.com)**

NOTE: Dimensions subject to change without notice. Please contact sales for detailed drawings.